

GETAWAY MARKETING, INC. REPRESENTING GLAVAL BUS

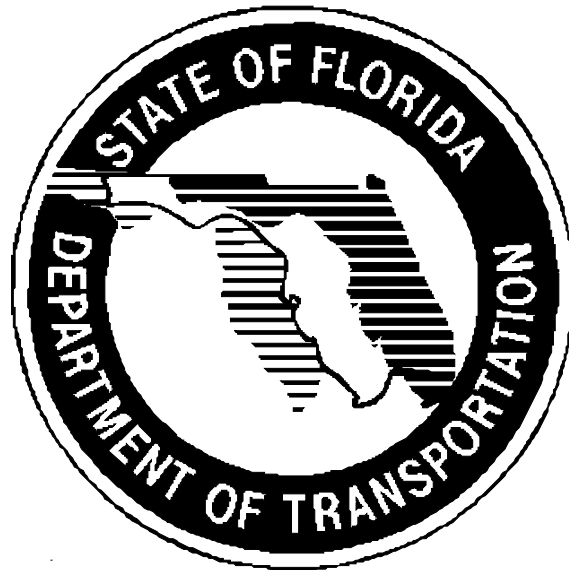

ORDER PACKET

Contract #FVPP-05-CA-4

**Cutaway Type Vehicles
Chev/GMC CC4500 Chassis
17,500# GVWR**

CONTRACT # FVPP-05-CA-4

**ORDER PACKET FOR
23', 25' and 27' GLAVAL CUTAWAYS
ON CHEV/GMC CC4500 GVWR CHASSIS WITH 17,500# GVWR
GETAWAY MARKETING, INC.**

General Information

The Florida Vehicle Procurement Program (FVPP) issued Proposal #FVPP-05-CA to establish a series of state contracts for the purchase of Body on Chassis Cutaway Type Vehicles. Through this process five contracts were awarded to two different vendors each representing a different vehicle manufacturer.

This Order Packet is for Contract #FVPP-05-CA-4, which was awarded to Getaway Marketing, Inc. on May 26, 2005, to provide Glaval Bus Cutaway Type Vehicles in lengths of 23, 25 and 27 feet on Chev/GMC CC4500 chassis with a Gross Vehicle Weight Rating (GVWR) of 17,500 pounds.

This Order Packet contains the necessary instructions and forms for agencies to place an order with Getaway Marketing to purchase these vehicles. This information can also be found at the FVPP website – <http://www.cutr.usf.edu/fvpp>. This Order Packet also provides guidance and clarity on the relationships between the seller, the buyer, and Florida DOT's FVPP.

The complete Contract #FVPP-05-CA-4 is accessible from the FVPP website. This 114 page document contains the following sections:

- **Part 1** - General Requirements and Conditions, and Contractual Provisions
(Including copies of all U.S. DOT Federal Transit Administration certifications)
- **Part 2** - Technical Specifications
- **Part 3** - Options
- **Part 4** - Quality Assurance Provisions
- **Part 5** - Warranty Provisions
- **Part 6** - Paint Schemes

For further information on the FVPP and Contract #FVPP-05-CA-4, please contact either Hank Cusack (813-974-7834) or Cindy Wooten (813-974-9771) at the University of South Florida Center for Urban Transportation Research (CUTR).

Vendor Information

To place an order for a vehicle under Contract #FVPP-05-CA-4, contact either Susan Gould or William Gould at Getaway Marketing, Inc.

- **Address:** Getaway Marketing, Inc.
4933 17th Street East
Bradenton, Florida 34203
- **Telephone #:** (941) 747-5486
(877) 287-7287 Toll Free
- **FAX #:** (941) 746-8834
- **Contact Persons:** Susan Gould or William Gould

Procedures for Ordering

The following sections provide guidance to be used by the vendor and the agencies in the ordering, delivery, acceptance and payment for vehicles procured under this contract. All parties are advised to fully review the full contract document available on the FVPP website. Contract #FVPP-05-CA-4 will be the governing document.

Agencies should understand that each order placed with and acknowledged by Getaway Marketing, Inc. constitutes a contract between the purchaser and Getaway Marketing, Inc. only. The contract implies no duties or responsibilities by the University of South Florida Center for Urban Transportation Research or the Florida Department of Transportation. The terms and conditions of this contract are to be administered and enforced by and between the agency and the vendor.

Ordering Instructions

Agencies must utilize the order forms in this Order Packet to place their orders. Agencies are encouraged to contact and work closely with Getaway Marketing, Inc. in finalizing their orders, to fully understand the options available, to select the floor plans and seating selections, the paint schemes, and any special options or conditions that may impact the final order and purchase price. Please submit a separate order form for each vehicle ordered.

Contract #FVPP-05-CA-4 is to provide Glaval Bus Cutaway Type Vehicles in lengths of 23, 25 and 27 feet on Chev/GMC CC4500 chassis with a Gross Vehicle Weight Rating (GVWR) of 17,500 pounds. Among the standard components of this vehicle are:

- Chevrolet/GMC CC4500 Chassis
- 6.6L DuraMax Chevrolet 300 HP diesel engine as standard
- Allison 1000PTS Pupil Transportation/Shuttle Series transmission Flat floor design
- Electric door opener as standard
- Multiple floor layouts and seating options
- Choice of wheelchair lift types and models

- Choice of wheelchair securement systems
- Several standard paint schemes
- Several options

Most agencies already have an idea on the type and number of seats and wheelchair positions needed to meet their floor plan requirements. A wide variety of floor plans are available. Agencies should work closely with Getaway Marketing, Inc. to develop and finalize their floor layout plans. Based upon this consultation, Getaway Marketing, Inc. will develop a proposed floor plan based on the Agency's needs and fax a copy of the plan to the Agency for verification and approval.

The Order Packet also includes illustrations of the basic vehicle paint schemes and the description of the available options to assist the Agency in completing your orders.

Included in this Order Packet are the following forms and information:

- Order Form that provides:
 - Base vehicle prices
 - Unit seating and wheelchair station prices
 - Paint scheme options and prices
 - Individual option and prices
 - Sample choice forms
- Sample Order Form – providing an example as how to complete the order form
- Description of Options
- Available Paint Schemes

Please submit a separate order form for each vehicle ordered. After determining the length of bus, floor plan, paint scheme and desired individual options, to complete the order form place the number of items in the corresponding quantity column. Multiply the dollar figure in the cost column by the number of items in the quantity column to calculate a total cost for that item. Enter that amount in the total cost column. Add the total cost column amounts together to arrive at the grand total for the vehicle. The grand total will be the figure used on the Agency's purchase order.

Unless your vehicle is funded in part by the FTA Section 5310 grant program, the Agency deals directly with Getaway Marketing, Inc.

Once the details of the order are finalized, an Agency Purchase Order payable to Glaval Bus, A Division of Forest River, Inc. must accompany all orders placed with Getaway Marketing, Inc. for those vehicles funded outside the FTA Section 5310 grant program.

For all vehicles funded through the FTA Section 5310 grant program, a copy of the completed order form and either an Agency purchase order or a check for the Agency's portion payable to Glaval Bus, A Division of Forest River, Inc. must to emailed, faxed or mailed to the CUTR Section 5310 Program Coordinator:

Ms. Cindy Wooten
CUTR Section 5310 Program Coordinator
USF-CUTR
4202 E. Fowler Avenue – CUT100
Tampa, Florida 33620
Telephone: (813) 974-9771
Fax: (813) 396-9345

The CUTR Section 5310 Program Coordinator will verify the order accuracy, complete the request for the FDOT share, and forward the request to Tallahassee for the FDOT purchase order. When the FDOT purchase order number is assigned, the CUTR Section 5310 Program Coordinator will place the order with Getaway Marketing, Inc. and notify the Agency of the status.

Getaway Marketing, Inc. will provide written confirmation to the Agency and/or CUTR of the receipt of the order within seventy-two (72) hours of receiving the order with purchase order. At a minimum, the acknowledgement of the order will contain:

- The Agency's purchase order number
- The date the order was received
- The date the order was placed with the manufacturer
- The production and VIN number when available
- The estimated delivery date (when available)

Delivery

Completed units must be delivered to Agency within ninety (90) days from receipt of chassis or purchase order, whichever occurs last.

In the event of delay in completion of the delivery of vehicles beyond the date specified in the contract, in addition to any granted extensions agreed to in writing by the Agency, the Agency may assess as liquidated damages, twenty five dollars (\$25.00) per calendar day per vehicle.

Each vehicle purchased through the FVPP shall be routed to the FDOT's Springhill Inspection Facility, located in Tallahassee, Florida, for an inspection prior to delivery to Getaway Marketing, Inc.

Getaway Marketing, Inc. should see that all noted write-ups are corrected prior to final delivery to the procuring agency. This inspection by the FVPP is not represented as being "all inclusive" and in no way relieves the dealer from the required Pre-Delivery Inspection (PDI).

Prior to the vehicle(s) being delivered, Getaway Marketing must perform a PDI. Upon completion of a PDI, Getaway Marketing, Inc. will be required to deliver the vehicles to the Purchaser. The dealer shall notify both the purchasing Agency and the FDOT District

Office a minimum of 48 hours in advance to arrange a delivery time.

The vehicle shall be delivered with all Contractor/manufacturer's quality control checklists including road test and final inspection (properly completed and signed by an authorized plant representative). Other documents/items required at delivery include:

- Manufacturer's Certificate of Origin
- Application for Certificate of Title
- Bill of Sale
- Warranty Papers (forms, policy, procedures)
- Maintenance Schedule
- Operators' manual
- Invoice (To include contract number, P.O. number, VIN#, and agency name)

Final Acceptance

Delivery of the vehicle(s) by Getaway Marketing, Inc. does not constitute acceptance by the Agency. The vehicle will be considered "accepted" upon passing the inspection and issuance of an acceptance letter by the Agency.

The terms of the contract state that an Agency has ten (10) calendar days after receiving the vehicle(s) to perform the Post Delivery Inspection and issue either a "Letter of Acceptance" or a "Letter of Rejection" to Getaway Marketing, Inc. and the Florida DOT District Office contact. The "Letter of Rejection" will state and describe the areas to be found in noncompliance with the bid specifications, incompleteness, or any defective or damaged parts.

A vehicle should be rejected if any items are missing, defective, altered, incorrect, or incomplete. In the event a vehicle(s) is delivered incomplete or contains any defective or damaged parts, the said parts will be removed and replaced by Getaway Marketing, Inc. New parts will be furnished and installed by Getaway Marketing, Inc. at no cost to the Agency. If there is work involved, warranty or otherwise, to repair or place the vehicle(s) in proper complete condition, such repairs will be made by an approved firm in accordance to the warranty provisions of the contract.

Placing the vehicle(s) in revenue service will automatically constitute "acceptance". In such circumstances, a "Letter of Acceptance" should still be sent to Getaway Marketing, Inc.

Acceptance of the vehicles shall not release the Contractor from liability for faulty workmanship or materials.

Payment

For vehicle purchased without funding from the FTA Section 5310 grant program, the Agency should complete all necessary paperwork and submit its request to process the Agency purchase order payment to Glaval Bus, A Division of Forest River, Inc. within five (5) days after the delivery and/or acceptance of the vehicle.

The remittance information is: Glaval Bus, A Division of Forest River, Inc.
Attn: Bert Borkholder
914 County Road 1
Elkhart, IN 46514

For all vehicles funded through the FTA Section 5310 grant program, the Agency should approve and process its purchase order to allow a check for the Agency amount to be sent to Glaval Bus, A Division of Forest River, Inc. for its share of the vehicle. If, instead of a purchase order, a check was provided at the order request time, forward all invoices to the CUTR Section 5310 Program Coordinator along with the acceptance letter.

Upon receipt of the Agency's portion of the vehicle, Getaway Marketing, Inc. will contact the CUTR Section 5310 Program Coordinator with a request to process the FDOT purchase order payment approval.

The remittance information is: Glaval Bus, A Division of Forest River, Inc.
Attn: Bert Borkholder
914 County Road 1
Elkhart, IN 46514

The total purchase price should be paid in full within sixty (60) days after acceptance of each vehicle. Agencies should note that failure to meet the net 60-day payment terms could result in the assessment of interest and other penalties. Terms are those shown in Price Proposal Form F of the contract document. A 2% monthly service charge will be added to all past due accounts.

EXHIBIT A

ORDER FORM

**REVISED March 2009 to include 14,200 #GVWR GMC Chassis;
Ford E-450 Chassis; and
Azure Dynamic Parallel Hybrid Electric Ford E-450 Chassis**

ORDER FORM – PAGE ONE

CONTRACT # FVPP-05-CA-4
ORDER FORM FOR, 23', 25' and 27' GLAVAL CUTAWAYS
ON CHEVY GMC CC4500 GVWR CHASSIS WITH 17,500# GVWR
Ford E-450 Hybrid 22' 14,050 GVWR
22' Chevy CC4500 EXPRESS 14,200 GVWR
22' Ford E-450 w/14,500 GVWR
GETAWAY MARKETING, INC.

AGENCY NAME: _____ **DATE:** _____

PURCHASE ORDER NUMBER: _____ **E-Mail:** _____

CONTACT PERSON: _____
(Name and Telephone Number)

December 2009

Item	Unit Cost	Quantity	Total Cost
Base Vehicle Type			
Chevy Express4500 22 Foot 14,200 GVWR Std. Diesel	\$65,197		
Chevy GMC 4500 23 Foot 17,500 GVWR Std. Diesel	\$72,000		
Chevy GMC 4500 25 Foot 17,500 GVWR Std. Diesel	\$72,675		
Chevy GMC 4500 27 Foot 17,500 GVWR Std. Diesel	\$74,273		
Ford E-450 22 Foot 14,500 GVWR 6.8L Std. Gas Only	\$58,412		
Ford E-450 Hybrid 22 Foot 14,050 GVWR Std Gas Only	\$105,563		
Paint Scheme Choices			
Scheme #1	\$875		
Scheme #2	\$625		
Scheme #3	\$575		
Floor Plan Choices (pick one brand)			
<i>Freedman Seats (Standard)</i>			
Standard Seat (per person)	\$212		
Fold-away Seat (per person)	\$331		
Child's Seat (per person)	\$241		
<i>American Seating(Option)Without 3-point tie-down)</i>			
Standard Seat (per person)	\$183.50		
Fold-away Seat (per person)	\$280		
Child's Seat (per person)	\$202.50		
<i>Securement Systems (pick one style)</i>			
Q'Straint QRTMAX (per position)	\$387		
Sure-Lok Model FF600AL (per position)	\$387		
PAGE ONE SUB-TOTAL		----	----

ORDER FORM – PAGE TWO
CONTRACT # FVPP-05-CA-4
GETAWAY MARKETING, INC.

December 2009

Item	Unit Cost	Quantity	Total Cost
Side Wheelchair Lift Choices (pick one)			
Braun N919	\$2,195		
Braun Vista V919	\$2,195		
Ricon S-2010	\$2,195		
Ricon Klearview K2010	\$2,195		
Maxon WL-733L	\$2,195		
Other Available Options			
HELP Bumper Rear with Hawkeye System	\$340		
Altro Flooring	\$245		
Gasoline Engine 8100 VORTEC Chev 325 HP 4500 Model Only	-\$6,557		
Gasoline Engine 6.0 Litre V8 4500 Express 22 Foot Model Only	-\$6,285		
Aluminum Wheels (in place of steel wheels)	\$937		
Freedman CL 67 Air Suspension Driver's Seat	\$780		
Freedman Sport Seat with Relaxor	\$305		
REI Public Address System	\$410		
Additional Seat Belt Extenders (2 provided as standard w/order)	\$17		
AM/FM Radio	\$168		
Manual Entry Door (in place of electric door)	Standard		
TELMA Retarder	\$5,250		
Stainless Steel Wheel Inserts	\$242		
Merlin Multiplex Electrical System	Standard		
Tacholink Event Data Recorder			
Operator "Smart Tag" Button (1 per driver)	\$40		
Button Reader (1 per depot)	\$120		
Digital Smart Module (1per depot)	\$170		
DSM Reader (1 per Depot)	\$75		
RF Vehicle Interface (1per bus)	\$360		
RF Base Station Receiver (1 per depot)	\$570		
Bus Location & Mapping			
Historic GPS Receiver (1per bus)	\$440		
Mapping Software & maps (1 per depot)	\$1000		
PAGE TWO SUB-TOTAL	---	---	

PAGE TWO SUB-TOTAL <i>(carry forward from previous page)</i>	----	----	
PAGE ONE SUB-TOTAL <i>(carry forward from previous page)</i>	----	----	
GRAND TOTAL <i>(sum of page 1 and 2 sub-totals)</i>	----	----	

CHOICES ORDER FORM

CONTRACT # FVPP-05-CA-4

GETAWAY MARKETING, INC.

SEATING AND FLOORING CHOICES

Seating Colors: (circle one) Blue Gray Beige

Flooring Colors: (circle one) Blue Gray Beige Black

Paint Scheme: (circle one) #1 #2 #3

Paint Schemes: Agencies will select colors (2) for background and stripes when orders are placed. All paint scheme pricing shall reflect white base coat. If an agency requires a paint and lettering scheme that is NOT GENERALLY covered by one of those listed above, they may make separate arrangements either with the manufacturer or a local vendor to provide these services.

Upholstery Information-Vinyl Colors Available:

Blue Vinyl Combo: Center insert of seat to be Blue/Gray Print CMI part # VP-MEDLI-KEAZU, Outside wrap and back of seat to be Blue solid CMI part # VP-MEDLI-TRAZU.

Gray Vinyl Combo: Center insert of seat to be Blue/Gray Print CMI part # VP-MEDLI-KEAZU, Outside wrap and back of seat to be Gray solid CMI part # VP-MEDLI-TRGRY.

Beige Vinyl Combo: Center insert of seat to be Beige Print CMI part # VP-MEDLI-KEVER, Outside wrap and back of seat to be Beige solid CMI part # VP-MEDLI-DOSNB.

WHEELCHAIR LIFT CHOICE

Wheelchair Lift: (circle one) Braun N919 Braun Vista V919
Ricon S-2010 Ricon Klearview K2010
Maxon WL-733L

SECUREMENT RETRACTOR CHOICE

W/C Securement: (circle one) Q'Straint Sure-Lok
QRTMAX Model FF600AL

Event Data Recorder Channel System Selections

As detailed in Section 2.45 of the Technical Specifications, an event data recorder (EDR), Circuitlink International “Tacholink”, (or approved equal) will be mounted on each vehicle.

The EDR will provide a continuous log of vehicle activity. Speed history, odometer, excessive RPM, heavy braking, fast acceleration, idling exceptions will automatically recorded by exception. In the event of an accident, all data shall be permanently captured in “tamperproof” flash memory (4MB minimum) for a minimum of (30) seconds prior to the incident and (15) seconds after the incident at a minimum interval of 25 milliseconds.

The EDR will provide an automatic trigger function with different user definable thresholds for moving and stationary conditions. A manual driver alert button will be provided to allow driver “tagging” of either an accident or vehicle fault condition shall be located behind upper bulkhead and must be accessible through a latching door.

All software for user configuration, data logging, and downloading and report generation will be included. All software will be Windows-based. Trip data will be stored in Microsoft Access database. All data will be the property of Florida DOT and will be immediately available to Florida DOT. There will be no additional charges, for hardware and/or software services or annual fees will be incurred by Florida DOT or any operator.

Additional digital input channels will be provided to allow for status monitoring of a maximum of eight (8) vehicle sub-systems. Standard systems that will be monitored shall be: brakes, lights, signals, flashers, driver’s seat belt, wheelchair lift, engine temperature and front door. Each agency may substitute any of the standard systems detailed above with any of the following optional systems: oil pressure, low air pressure, low voltage, or emergency exit door. The limit of the total systems to be monitored is eight (8).

Below, please indicate the eight (8) vehicle sub-systems to be monitored on this vehicle. If no selection made, the standard systems will be programmed. For each of the optional systems you select, you must not include one of the standard system selections. A limit of eight (8) total systems per bus can be monitored.

Select Eight Systems To Be Monitored (Maximum of Eight (8))			
STANDARD SYSTEMS		OPTIONAL SYSTEMS	
	1. Brakes		9. Oil Pressure
	2. Lights		10. Low Air Pressure
	3. Signals		11. Low Voltage
	4. Flashers		12. Emergency Door Exit
	5. Driver’s Seat Belt		
	6. Wheelchair Lift		
	7. Engine Temperature		
	8. Front Door		

EXHIBIT B

SAMPLE ORDER FORM

**REVISED March 2009 to include 14,200 #GVWR GMC Chassis;
Ford E-450 Chassis; and
Azure Dynamic Parallel Hybrid Electric Ford E-450 Chassis**

SAMPLE ORDER FORM – PAGE ONE

CONTRACT # FVPP-05-CA-4
ORDER FORM FOR 22', 23', 25' and 27' GLAVAL CUTAWAYS
ON CHEV/GMC CC4500 GVWR CHASSIS WITH 17,500# GVWR
Ford E-450 Hybrid 22' 14,050 GVWR
GETAWAY MARKETING, INC.

AGENCY NAME: _____ **DATE:** _____

PURCHASE ORDER NUMBER: _____ **E-MAIL** _____

CONTACT PERSON: _____
(Name and Telephone Number)

December 2009

Item	Unit Cost	Quantity	Total Cost
Base Vehicle Type			
Chevy Express 4500 22 Foot 14,200 GVWR	\$65,197		
Chevy GMC CC4500 23 Foot 17,500 GVWR	\$72,000		
Chevy GMC CC4500 25 Foot 17,500 GVWR	\$72,675	1	\$72,675
Chevy GMC CC4500 27 Foot 17,500 GVWR	\$74,273		
Ford E-450 22 Foot 14,500 GVWR 6.8L Std. Gas	\$58,412		
Ford E-450 Hybrid 22 Foot 14,050 GVWR	\$105,563		
Paint Scheme Choices			
Scheme #1	\$875		
Scheme #2	\$625		
Scheme #3	\$575	1	\$575
Floor Plan Choices (pick one brand)			
<i>Freedman Seats (Standard)</i>			
Standard Seat (per person)	\$212	6	\$1,272
Fold-away Seat (per person)	\$331	6	\$1,986
Child's Seat (per person)	\$241		
<i>American Seating (Option)</i> <i>(without 3-point tie-down)</i>			
Standard Seat (per person)	\$183.50		
Fold-away Seat (per person)	\$280		
Child's Seat (per person)	\$202.50		
<i>Securement Systems (pick one style)</i>			
Q'Straint QRTMAX (per position)	\$387		
Sure-Lok Model FF600AL (per position)	\$387	2	\$774
PAGE ONE SUB-TOTAL			\$77,282

SAMPLE ORDER FORM – PAGE TWO

CONTRACT # FVPP-05-CA-4
ORDER FORM FOR 22', 23', 25' and 27' GLAVAL CUTAWAYS
ON CHEV/GMC CC4500 GVWR CHASSIS WITH 17,500# GVWR
Ford E-450 Hybrid 22' 14,050 GVWR
GETAWAY MARKETING, INC.

December 2009

Item	Unit Cost	Quantity	Total Cost
Side Wheelchair Lift Choices (pick one)			
Braun N919	\$2,195		
Braun Vista V919	\$2,195	1	\$2,195
Ricon S-2010	\$2,195		
Ricon Klearview K2010	\$2,195		
Maxon WL-733L	\$2,195		
Other Available Options			
HELP Bumper Rear with Hawkeye System	\$340	1	\$340
Altro Flooring	\$245	1	\$245
Gasoline Engine 8100 VORTEC Chev 325 HP	-\$6,557	1	-\$6,557
Gasoline Engine 6.0 Litre V8 4500 Express Model 22 Foot Only	-\$6,285		
Aluminum Wheels (in place of steel wheels)	\$937		
Freedman CL 67 Air Suspension Driver's Seat	\$780		
Freedman Sport Seat with Relaxor	\$305		
REI Public Address System	\$410	1	\$410
Additional Seat Belt Extenders (2 provided w/order)	\$17		
AM/FM Radio	\$168		
Manual Entry Door (in place of electric door)	Standard		
TELMA Retarder	\$5,250		
Stainless Steel Wheel Inserts	\$242	1	\$242
Merlin Multiplex Electrical System	Standard		
Tacholink Event Data Recorder			
Operator "Smart Tag" Button (1 per driver)	\$40		
Button Reader (1 per depot)	\$120		
Digital Smart Module (1per depot)	\$170		
DSM Reader (1 per Depot)	\$75		
RF Vehicle Interface (1per bus)	\$360		
RF Base Station Receiver (1 per depot)	\$570		
Bus Location & Mapping			
Historic GPS Receiver (1per bus)	\$440		
Mapping Software & maps (1 per depot)	\$1000		

<p>PAGE TWO SUB-TOTAL <i>(sub-total of this page)</i></p>	----	----	-\$3,125
<p>PAGE ONE SUB-TOTAL <i>(carry forward from previous page)</i></p>	----	----	\$77,282
<p>GRAND TOTAL <i>(sum of page 1 and 2 sub-totals)</i></p>	----	----	\$74,157

SAMPLE CHOICES FORM

CONTRACT # FVPP-05-CA-4

**ORDER FORM FOR 23', 25' and 27' GLAVAL CUTAWAYS
ON CHEV/GMC CC4500 GVWR CHASSIS WITH 17,500# GVWR**

GETAWAY MARKETING, INC.

SEATING AND FLOORING CHOICES

Seating Colors: (circle one) Blue Gray Beige

Flooring Colors: (circle one) Blue Gray Beige Black

Paint Scheme: (circle one) #1 #2 #3

Paint Schemes: Agencies will select colors (2) for background and stripes when orders are placed. All paint scheme pricing shall reflect white base coat. If an agency requires a paint and lettering scheme that is NOT GENERALLY covered by one of those listed above, they may make separate arrangements either with the manufacturer or a local vendor to provide these services.

Upholstery Information-Vinyl Colors Available:

Blue Vinyl Combo: Center insert of seat to be Blue/Gray Print CMI part # VP-MEDLI-KEAZU, Outside wrap and back of seat to be Blue solid CMI part # VP-MEDLI-TRAZU.

Gray Vinyl Combo: Center insert of seat to be Blue/Gray Print CMI part # VP-MEDLI-KEAZU, Outside wrap and back of seat to be Gray solid CMI part # VP-MEDLI-TRGRY.

Beige Vinyl Combo: Center insert of seat to be Beige Print CMI part # VP-MEDLI-KEVER, Outside wrap and back of seat to be Beige solid CMI part # VP-MEDLI-DOSNB.

WHEELCHAIR LIFT CHOICE

Wheelchair Lift: (circle one) Braun N919 Braun Vista V919
Ricon S-2010 Ricon Klearview K2010
Maxon WL-733L

SECUREMENT RETRACTOR CHOICE

W/C Securement: (circle one) Q'Straint QRTMAX Sure-Lok Model F600AL

Event Data Recorder Channel System Selections

As detailed in Section 2.45 of the Technical Specifications, an event data recorder (EDR), Circuitlink International “Tacholink”, (or approved equal) will be mounted on each vehicle.

The EDR will provide a continuous log of vehicle activity. Speed history, odometer, excessive RPM, heavy braking, fast acceleration, idling exceptions will automatically recorded by exception. In the event of an accident, all data shall be permanently captured in “tamperproof” flash memory (4MB minimum) for a minimum of (30) seconds prior to the incident and (15) seconds after the incident at a minimum interval of 25 milliseconds.

The EDR will provide an automatic trigger function with different user definable thresholds for moving and stationary conditions. A manual driver alert button will be provided to allow driver “tagging” of either an accident or vehicle fault condition shall be located behind upper bulkhead and must be accessible through a latching door.

All software for user configuration, data logging, and downloading and report generation will be included. All software will be Windows-based. Trip data will be stored in Microsoft Access database. All data will be the property of Florida DOT and will be immediately available to Florida DOT. There will be no additional charges, for hardware and/or software services or annual fees will be incurred by Florida DOT or any operator.

Additional digital input channels will be provided to allow for status monitoring of a maximum of eight (8) vehicle sub-systems. Standard systems that will be monitored shall be: brakes, lights, signals, flashers, driver’s seat belt, wheelchair lift, engine temperature and front door. Each agency may substitute any of the standard systems detailed above with any of the following optional systems: oil pressure, low air pressure, low voltage, or emergency exit door. The limit of the total systems to be monitored is eight (8).

Below, please indicate the eight (8) vehicle sub-systems to be monitored on this vehicle. If no selection made, the standard systems will be programmed. For each of the optional systems you select, you must not include one of the standard system selections. A limit of eight (8) total systems per bus can be monitored.

Select Eight Systems To Be Monitored (Maximum of Eight (8))			
STANDARD SYSTEMS		OPTIONAL SYSTEMS	
XX	1. Brakes	XX	9. Oil Pressure
	2. Lights	XX	10. Low Air Pressure
XX	3. Signals	XX	11. Low Voltage
XX	4. Flashers		12. Emergency Door Exit
	5. Driver’s Seat Belt		
XX	6. Wheelchair Lift		
XX	7. Engine Temperature		
	8. Front Door		

EXHIBIT C

OPTIONS

OPTIONS

CONTRACT # FVPP-05-CA-4
ORDER FORM FOR 22', 23', 25' and 27' GLAVAL CUTAWAYS
ON CHEVY GMC CC4500 GVWR CHASSIS
FORD E-450 and E-450 WITH HYBRID DRIVE
GETAWAY MARKETING, INC.

3.1.0 AMERICAN SEATING (without 3-point tie down)

- 3.1.1 Standard seat (includes retractable seat belt assembly attached to the seat frame)
- 3.1.2 Foldaway seat (includes retractable seat belt assembly attached to the seat frame)
- 3.1.3 Child seat (includes retractable seat belt assembly attached to the seat frame)

3.2.0 HELP BUMPER-REAR

- 3.2.1 Rear energy absorbing HELP bumper by Romeo Rim assembled rear HELP bumper with HawKEye Reverse Assistance System (Romeo Rim HELP Guard) in place of standard rear HELP bumper. Or approved equal.

3.3.0 ALTRO FLOORING

- 3.3.1 Altro Transflor slip resistant sheet vinyl flooring, or equivalent.

3.4.0 ENGINE

The 8100 VORTEC Chevrolet 325 HP gasoline engine in place of the 6.6 DuraMax Chevrolet 300 HP diesel engine in the Chev/GMC chassis.

3.5.0 ALUMINUM WHEELS

- 3.5.1 Aluminum wheels in place of steel wheels.

3.6.0 DRIVER'S SEAT

- 3.6.1 Freedman CL 67 air suspension driver's seat with right hand arm rest in place of standard driver's seat.
- 3.6.2 Freedman Sport Driver's seat with Relaxor, four zone eight motor system with lumber heat in place of standard driver's seat.

3.7.0 PUBLIC ADDRESS SYSTEM

- 3.7.1 Radio Engineering Industries (REI) driver controlled public address.

3.8.0 SEAT BELT EXTENSIONS

3.8.1 Extends standard seat belt. Two seat belt extensions offered as standard. Extra seat belt extensions are available.

3.9.0 AM/FM RADIO

3.9.1 Installation of an AM/FM Radio with speakers is offered as standard no-cost item.

3.10.0 DOORS

3.10.1 The front service door shall be mechanically opened and closed by means of a driver actuated manually operated, door control. The door opening device shall be a manual over-center type with self locking adjustable length door control mechanism which can be easily operated by the driver from the driver's seat (e.g. school-bus type actuator handle). The door opening device stand shall be constructed of 1 x 2 inch (minimum) tubing with all tube bent corners, no 45 degree sharp welded ends mounted around engine cover and must not interfere with driver leg space. Stand may not be braced over the engine housing so as to interfere with removal of the cover. Stand shall not protrude past leading face of the engine cover, into the step well area.

3.11.0 RETARDER

3.11.1 The vehicle shall be equipped with a self air cooled, electro-magnetic, drive-line Telma retarder properly sized to meet vehicle specifications. Retarder shall be automatically and progressively activated upon depression of brake pedal. The retarder is to have four dash mounted lights which indicate stages and percentage of retarder engagement. A speed switch shall be provided to automatically discontinue the retarder when the vehicle comes to a stop. Retarder shall have an ABS interface. Design and installation shall be in accordance with industry standards as they pertain to drive-line design. Upon request there shall be a copy of engineering computations and drive-line conformity made available.

3.11.2 The installation of Telma retarders is no longer a dealer installed option. Any Telma retarder system must be installed by the manufacturer and be included in the As Built Wiring Schematics.

3.12.0 ADA DEVICES

3.12.1 Ricon wheel chair lift. (per Part 2)

3.12.2 Braun wheel chair lift. (per Part 2)

3.12.3 Maxon wheel chair lift. (per Part 2)

3.13.0 STAINLESS STEEL WHEEL INSERTS

3.13.1 Bus shall be equipped with stainless steel wheel liners/inserts both front and rear.

3.13.2 Wheel liners/inserts shall be Versa-Liner or equivalent.

3.13.3 Wheel liners/inserts shall be made of 304L stainless with permanently attached simulated lug nuts.

3.13.4 Wheel liners/inserts shall be one-piece design and must be designed to be attached without interfering with the lug nut to wheel surfaces.

3.14.0 WHEELCHAIR OR MOBILITY AID RETRACTOR SYSTEMS

3.14.1 Q'Straint QRTMAX

3.14.2 SURE-LOK Model #FF600AL

EXHIBIT D

PAINT SCHEMES

PAINT SCHEME #1

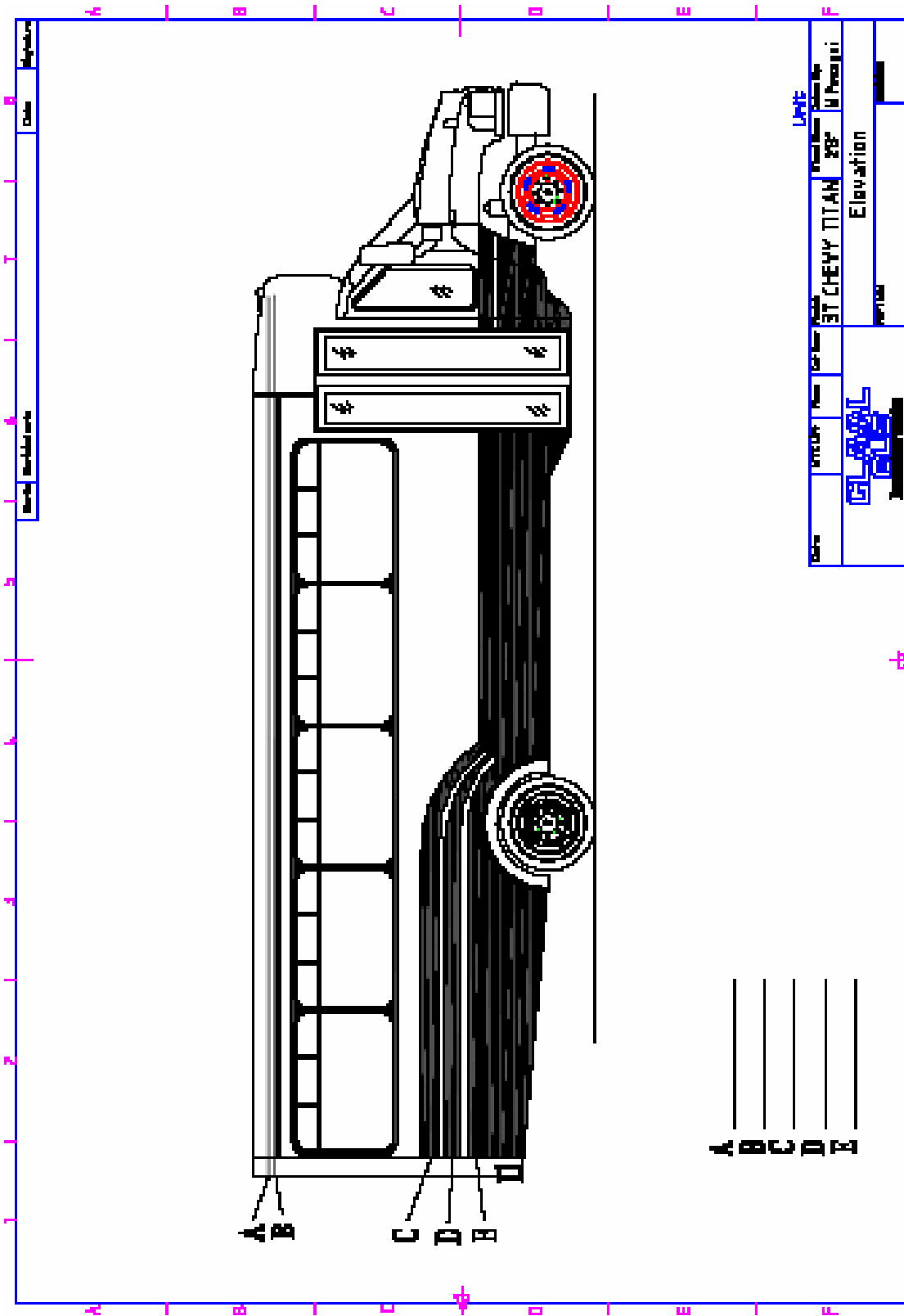

PAINT SCHEME #2

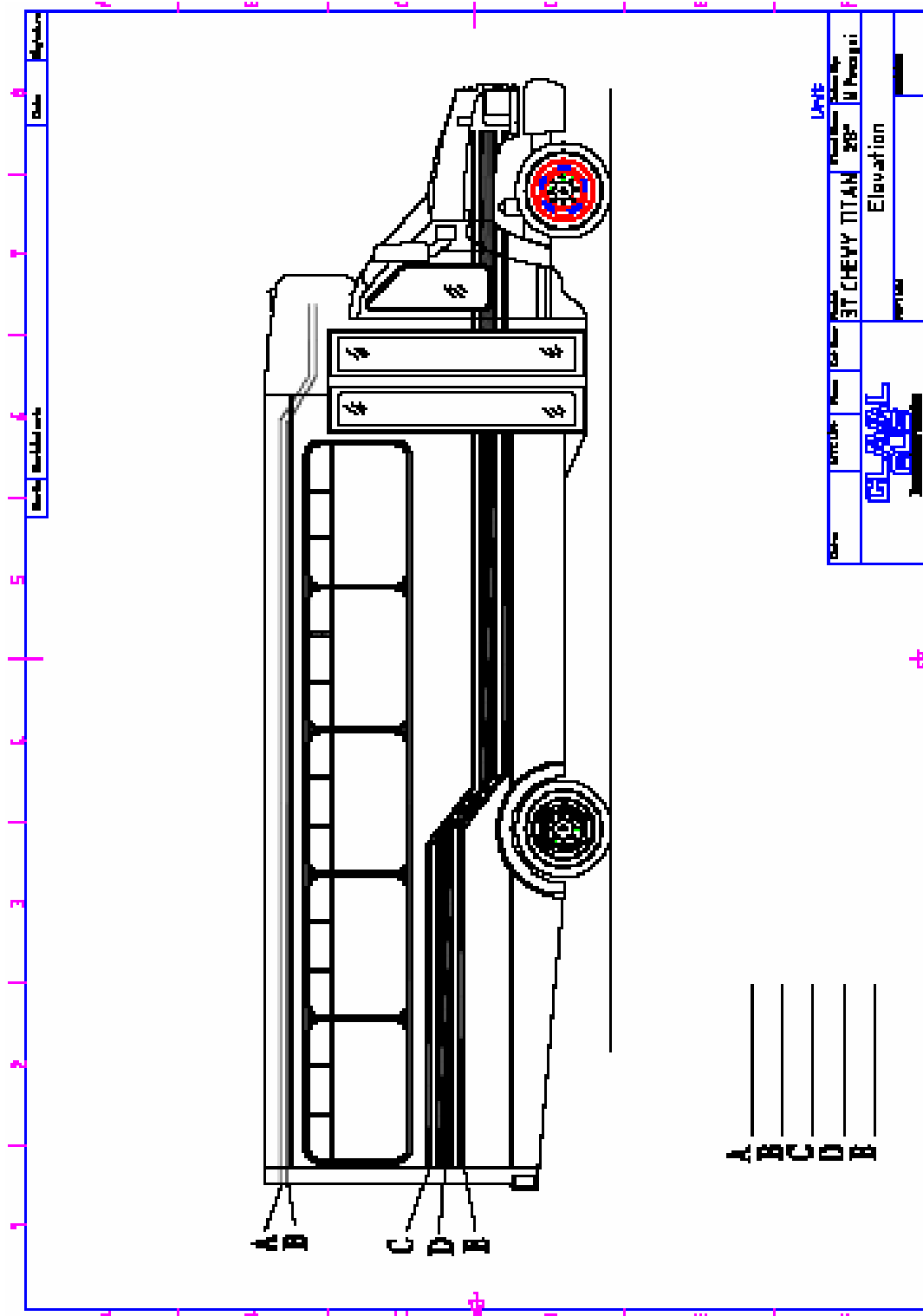

EXHIBIT E

SAMPLE FLOOR PLAN LAYOUTS

NOTE:

Most agencies already have an idea on the type and number of seats and wheelchair positions needed to meet their floor plan requirements. A wide variety of alternative floor plans are available.

Agencies should work closely with Getaway Marketing, Inc. to develop and finalize their floor layout plans. Based upon this consultation, Getaway Marketing, Inc. will develop a proposed floor plan based on the Agency's needs and fax a copy of the plan to the Agency for verification and approval.

